

HN

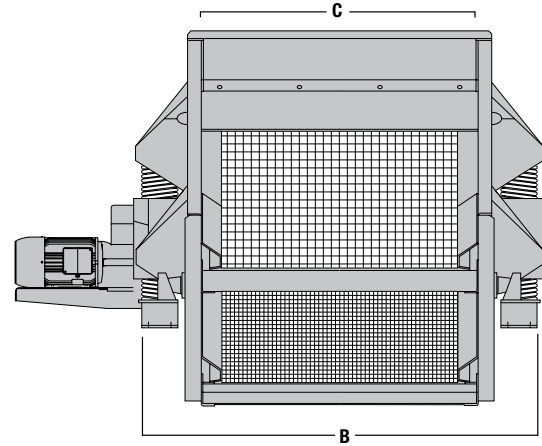

i SERIE HN

cribas_screens_сита

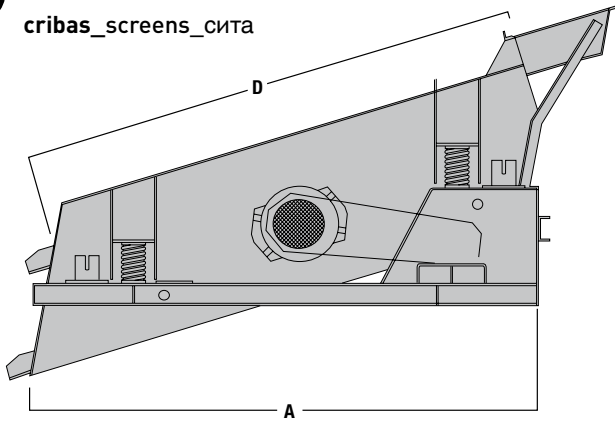

Model	↔	⚙️		⚡	⦿	A	B	C	D
	mm	m ²	Un	Kw	Un	mm	mm	mm	mm
HN 23-2 / HN 23-3 / HN 23-4	900 x 2.500	2,3	2 / 3 / 4	5,5 / 7,5 / 10	4/4/8	2.500	1.312	910	2.500
HN 36-2 / HN 36-3 / HN 45-4	1.200 x 3.000	3,6	2 / 3 / 4	7,5 / 10 / 15	8	2.600	1.880	1.208	3.000
HN 45-2 / HN 45-3	1.500 x 3.000	4,5	2 / 3	10 / 10	8	265	2.100	1.448	3.000
HN 60-2 / HN 60-3 / HN 60-4	1.500 x 4.000	6	2 / 3 / 4	15 / 15 / 15	8	3.600	2.240	1.460	4.000
HN 72-2 / HN 72-3 / HN 72-4	1.800 x 4.000	7,2	2 / 3 / 4	15 / 20 / 25	8	3.700	2.270	1.800	4.000
HN 90-2 / HN 90-3 / HN 90-4	1.800 x 5.000	9	2 / 3 / 4	7,5 / 10 / 19	8/8/16	4.700	2.700	1.800	5.000
HN 105-2 / HN 105-3	2.100 X 5.000	10,5	2 / 3	7,5 / 10 / 20	16	4.800	3.000	2.100	5.000
HN 120-2 / HN 120-3	2.100 X 5.800	12	2 / 3	7,5 / 10 / 21	16	5.410	3.000	2.030	5.800
HN 140-2	2.400 X 5.800	14	2	7,5 / 10 / 22	16	5.350	3.300	2.316	5.800
HN 170-2	2.400 X 7.200	170	2	7,5 / 10 / 23	16	6.710	3.300	2.316	7.200

↔ Dimensiones de bandeja
Dimensions of tray
Размеры лотка

⚙️ Superficie de cribado
Screening surface
Площадь просеивания

|| Número de bandejas
Number of trays
Количество лотков

⚡ Potencia
Power
Мощность

⦿ Muelles
Springs
Пружины

📏 Dimensiones
Dimensions
Размеры машины

📄 TABLA DE MÁQUINAS_TABLE OF MACHINES_СХЕМА МАШИИ

1. AVA_alimentadores_feeders_вибрационные питатели
2. MA_machacadoras_jaw crushers_щечковые дробилки
3. GEMINIS_molinos_crushers_дробилка
4. CVP_precribadores_pre screens_сита
5. AVM_alimentadores_feeders_вибрационные питатели
6. TAURO_molinos_crushers_дробилка
7. HN_cribas_screens_сита
8. LIBRA_molinos_crushers_дробилка
9. PISCIS_molinos_crushers_дробилка

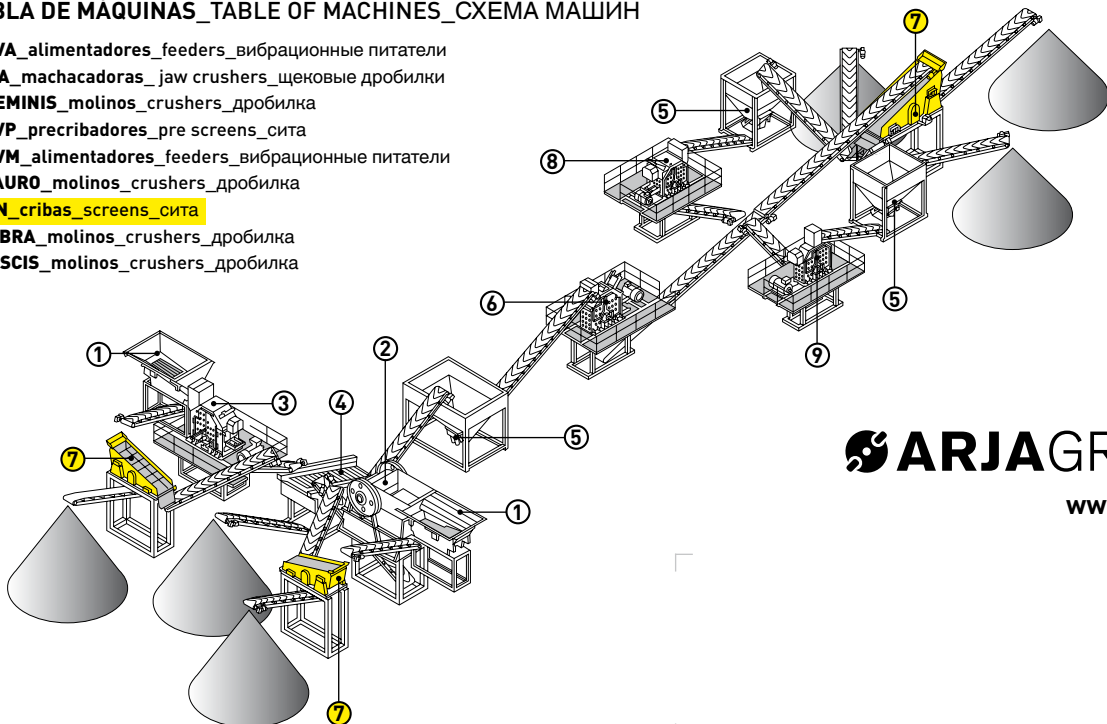

ARJAGROUP

www.arja.com